

## INSTRUCTIONS FOR MODELS

SE-490  
SE-495  
SE-580  
SE-582

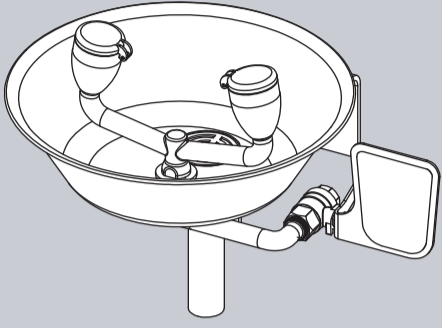

### NEED HELP?

For additional assistance or service please contact:

**SPEAKMAN**® Company  
400 Anchor Mill Road  
New Castle, DE 19720

800-537-2107

customerservice@speakman.com

www.speakman.com

92-SE-490-582-05

## TOOLS AND SUPPLIES

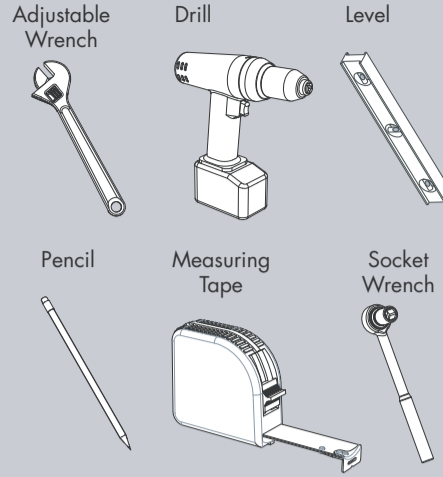

### IMPORTANT

ANSI Z358.1 states that weekly activation should be conducted on all plumbed emergency equipment to ensure that there is a suitable flushing fluid supply present and to clear the supply line of any sediment build-up that could prevent fluid from properly being delivered to the eye/eyeface wash device, as well as to minimize microbial contamination due to stagnant water. Also per the standard, the unit should be checked annually to ensure the unit still complies with the installation section (7.4) of the ANSI Z358.1 standard. ANSI Z358.1 specifies that the height of the spray heads is to be between 33" - 45" from the floor. The SE-490/495/580/582 unit shall be mounted ensuring the mounting surface (wall, etc.) and mounting hardware are sufficient to carry the load. Be sure to read instructions thoroughly before beginning installation. Do not overtighten any connections or damage may occur. SPEAKMAN furnishes a testing record tag (91-0635) with each unit. On this tag, the date of inspection and the inspector's initials should be noted.

### MAINTENANCE

Please reference the parts listing for the correct repair part numbers. Only use genuine SPEAKMAN parts when repairing or replacing components. To order parts, call 1-800-537-2107. Be sure to turn off water supplies before beginning any maintenance.

### SAFETY TIPS

Be sure to wear proper eye protection.

### WARRANTY

3 year limited warranty.  
Additional warranty information can be found at:  
www.speakman.com

**1** After selecting a suitable mounting location, measure to ensure the spray head height is between 33"- 45" from the floor. Mark and drill holes according to hardware selection specifications.

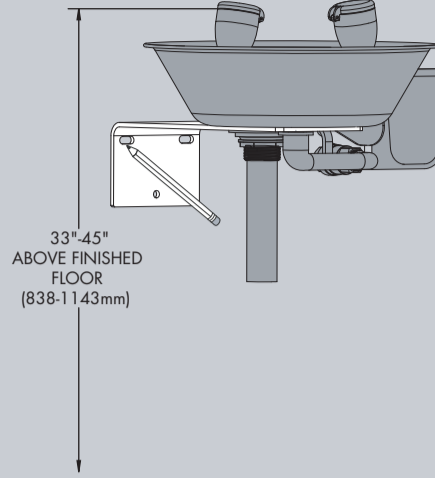

**2** Using appropriate hardware (not included), affix bowl to mounting surface. Ensure mounting hardware and structure are capable of supporting the product in use. Using a Level, confirm the bowl is both level and plum.

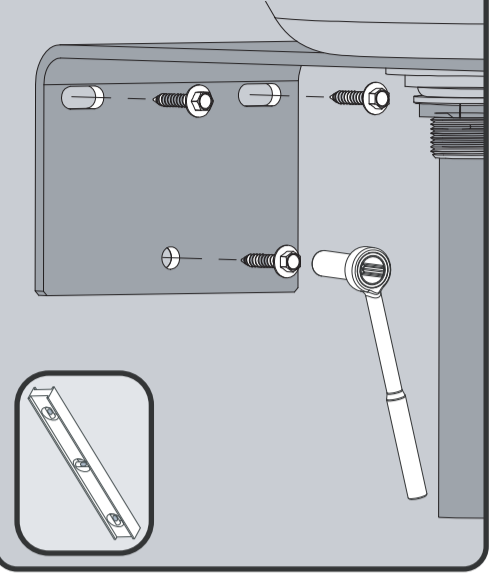

**3** Connect to an uninterrupted potable water supply with a minimum flowing pressure of 30psi and a maximum static pressure of 80psi to the 1/2" NPT female water supply inlet.

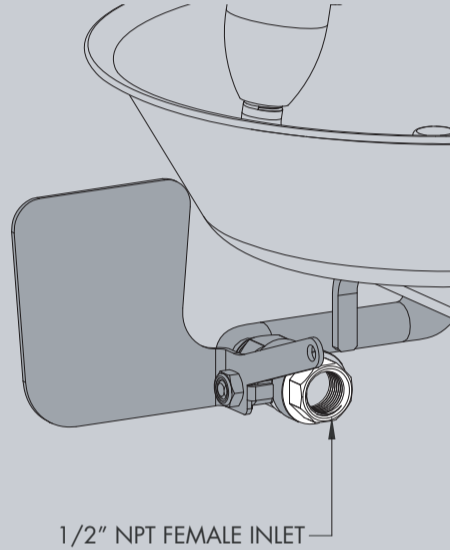

**4** Connect the drain trailpiece to an adequate drain in accordance with local plumbing codes.

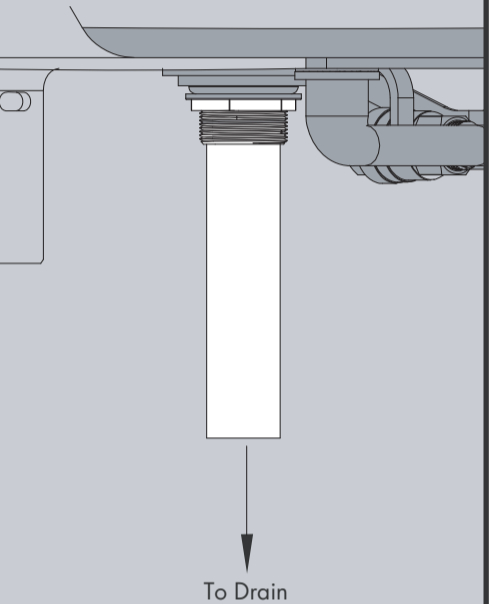

**5** To test, and for subsequent operation, push the Paddle Handle forward 90°. The unit will operate until the Paddle Handle is manually pulled back to the OFF position.

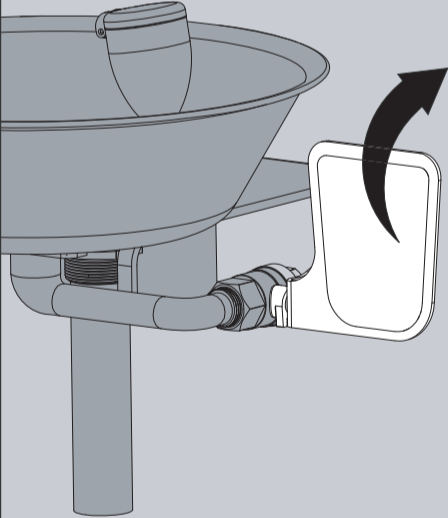

## SE-490 / SE-495 / SE-580 / SE-582 REPAIR PARTS

**SPEAKMAN**®

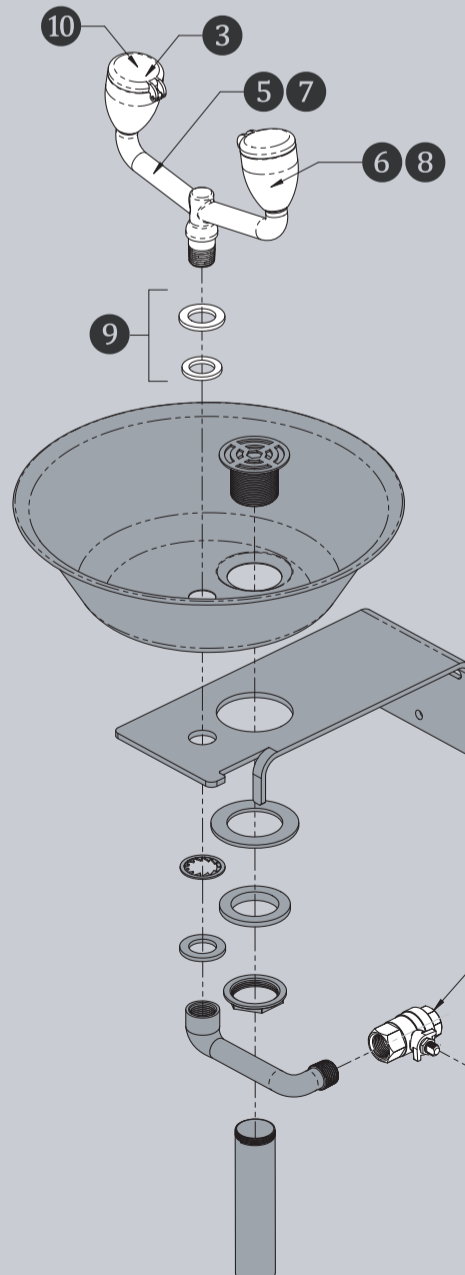

| ITEM NO. | PART NO.        | DESCRIPTION   |
|----------|-----------------|---|
| 1        | SE-910          | BRASS 1/2" BALL VALVE ASSEMBLY WITH PADDLE HANDLE           |
| 2        | SE-910-SSBV     | STAINLESS STEEL 1/2" BALL VALVE ASSEMBLY                    |
| 3        | RPG05-1177      | AERATOR REPLACEMENT GROUP (6 EACH)                          |
| 4        | RPG21-0082-PC-P | (NOT SHOWN) IN-LINE STRAINER REPAIR ASSEMBLY                |
| 5        | RPG05-0715      | SE-490 / SE-495 NON-AERATED EYE/FACE WASH BULLHORN ASSEMBLY |
| 6        | RPG38-0390      | SE-490 / SE-495 NON-AERATED SPRAYHEAD ASSEMBLY              |
| 7        | RPG05-0714      | SE-580 / SE-582 AERATED EYE/FACE WASH BULLHORN ASSEMBLY     |
| 8        | RPG38-0379      | SE-580 / SE-582 AERATED SPRAYHEAD ASSEMBLY                  |
| 9        | RPG05-0943      | BULLHORN WASHER GROUP                                       |
| 10       | RPG07-0104      | FLIP TOP DUST CAP REPLACEMENT (20 PER BAG)                  |

### FLOW DATA:

#### SE-490/495 FLOW DATA

| PRESSURE |      | FLOW RATE |       |
|----------|------|-----------|-------|
| psi      | bar  | gpm       | L/min |
| 30       | 2.07 | 4.5       | 17.0  |
| 60       | 4.14 | 4.6       | 17.4  |

#### SE-580/582 FLOW DATA

| PRESSURE |      | FLOW RATE |       |
|----------|------|-----------|-------|
| psi      | bar  | gpm       | L/min |
| 30       | 2.07 | 3.2       | 12.1  |
| 60       | 4.14 | 3.4       | 12.9  |

**NOTES:**

**COMPLIANCE:**

ANSI/ISEA Z358.1

**CONNECTIONS:**

- Inlet: 1/2" NPT Female
- Drain Outlet: 1-1/4"

Contractor to supply necessary inlet connections.

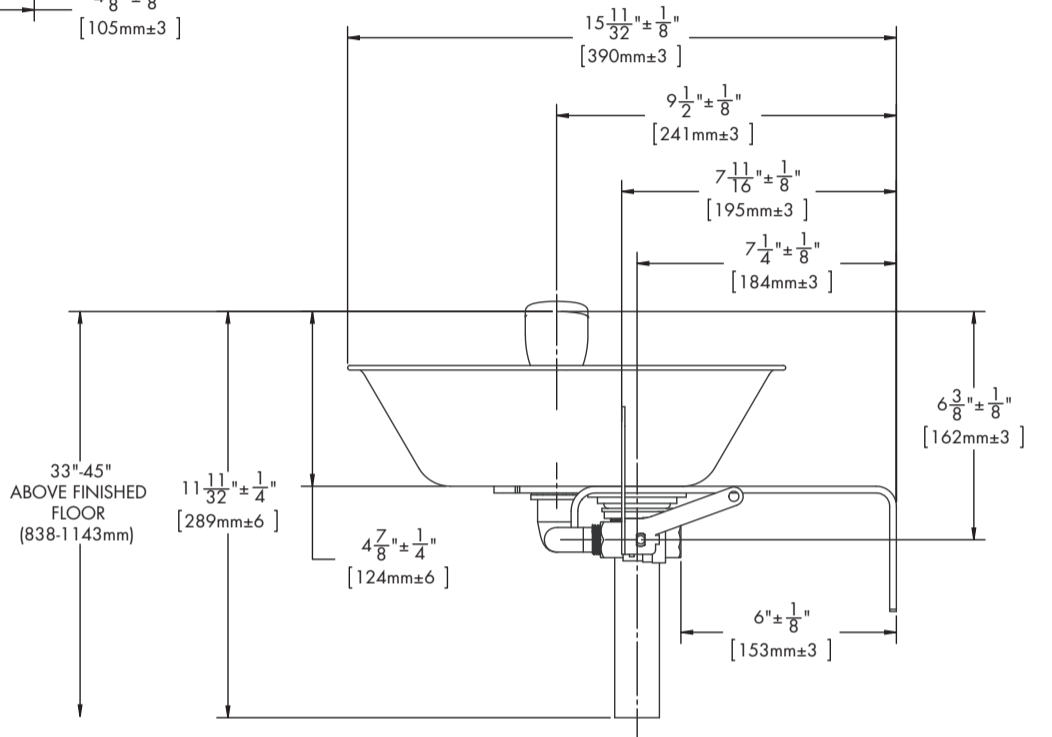
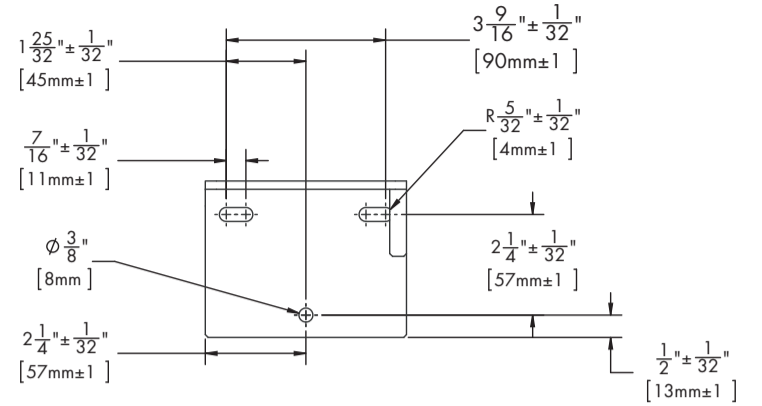
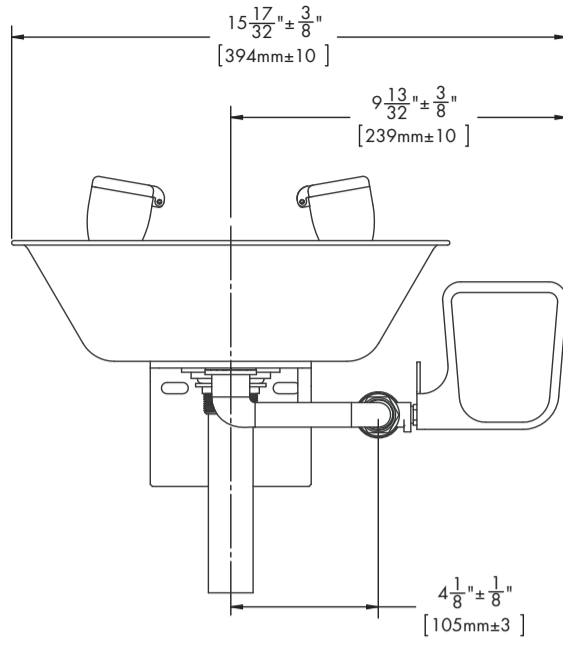

DIMENSIONS SUBJECT TO CHANGE WITHOUT NOTICE.

**NOTES:**

**COMPLIANCE:**

ANSI/ISEA Z358.1

**CONNECTIONS:**

- Inlet: 1/2" NPT Female
- Drain Outlet: 1-1/4"

Contractor to supply necessary inlet connections.

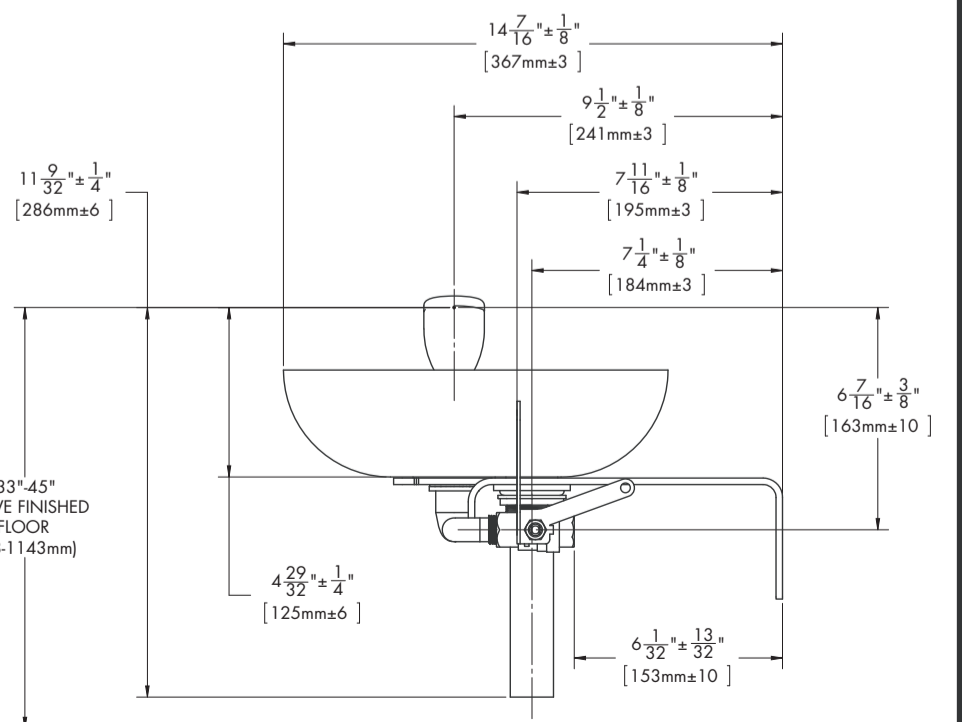
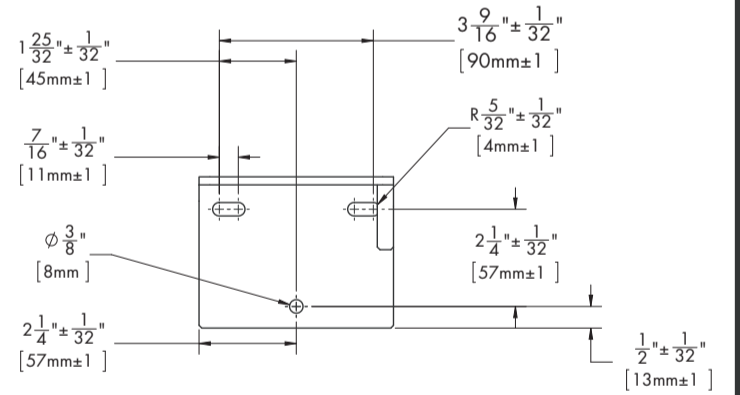
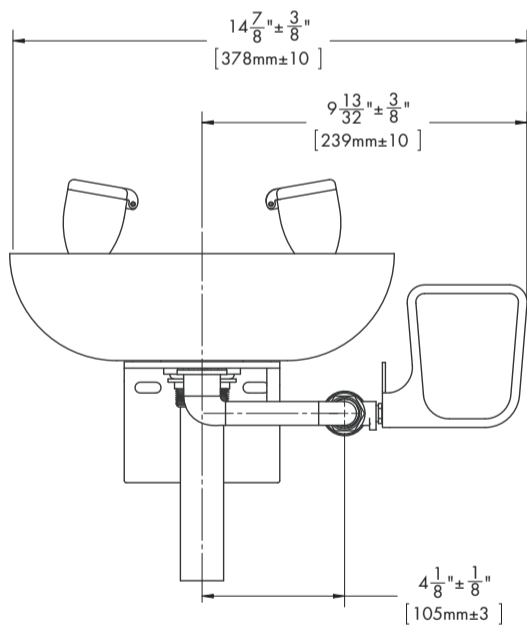

DIMENSIONS SUBJECT TO CHANGE WITHOUT NOTICE.